

Measurement of Spin-Exchange Effects in Electron-Hydrogen Collisions: 90° Elastic Scattering from 4 to 30 eV

G. D. Fletcher, M. J. Alguard,^(a) T. J. Gay, V. W. Hughes,
C. W. Tu,^(b) and P. F. Wainwright^(c)

J. W. Gibbs Laboratory, Yale University, New Haven, Connecticut 06520

and

M. S. Lubell

*J. W. Gibbs Laboratory, Yale University, New Haven, Connecticut 06520, and Physics Department,
The City College of the City University of New York, New York, New York 10031*

and

W. Raith

*J. W. Gibbs Laboratory, Yale University, New Haven, Connecticut 06520, and
The University of Bielefeld, Bielefeld, Federal Republic of Germany*

and

F. C. Tang

Physics Department, The City College of the City University of New York, New York, New York 10031

(Received 19 April 1982)

With use of a Fano-effect polarized electron source and a state-selected thermally dissociated hydrogen beam, the interference between the direct and the exchange scattering amplitudes was measured for 90° elastic scattering of electrons from atomic hydrogen for energies between 4 and 30 eV.

PACS numbers: 34.80.Bm

Earlier papers¹ discussed the application of crossed beams of polarized electrons and atoms to the study of spin-exchange effects in impact ionization of atomic hydrogen. This Letter reports the measurement of spin-exchange effects in 90° elastic scattering of electrons by hydrogen atoms from 4 to 30 eV. The basic quantity which we determine is the asymmetry $A_{90^\circ}(1S \rightarrow 1S)$ defined by

$$A_{90^\circ}(1S \rightarrow 1S) = (d\sigma_{\uparrow\downarrow} - d\sigma_{\uparrow\uparrow}) / (d_{\uparrow\downarrow} + d\sigma_{\uparrow\uparrow}), \quad (1)$$

where $d\sigma_{\uparrow\downarrow}$ and $d\sigma_{\uparrow\uparrow}$ are the 90° elastic differential scattering cross sections for incident-electron and hydrogen-electron spins antiparallel ($\uparrow\downarrow$) and parallel ($\uparrow\uparrow$). In terms of the direct and exchange 90°-elastic-scattering amplitudes, $f(90^\circ)$ and $g(90^\circ)$, respectively, $A_{90^\circ}(1S \rightarrow 1S)$ can be expressed as^{1,2}

$$A_{90^\circ}(1S \rightarrow 1S) = (1 - r) / (1 + 3r) = \text{Re}(f * g) / d\bar{\sigma}, \quad (2)$$

where $r \equiv |f - g|^2 / |f + g|^2$ is the triplet-to-singlet cross-section ratio and $d\bar{\sigma}$ is the spin-averaged differential cross section given by the weighted sum of the singlet and triplet cross sections, or

$$d\bar{\sigma} = \frac{1}{4}|f + g|^2 + \frac{3}{4}|f - g|^2. \quad (3)$$

Theoretically, electron-hydrogen elastic scattering is the simplest and most fundamental of all electron-atom collision problems. Nonetheless, it cannot be solved in closed form. Below the $n=2$ excitation threshold (10.2 eV), the detailed Kohn variational computations of s -, p -, and d -wave phase shifts³ are generally regarded as accurate to at least 1 mrad. In addition, polarized orbital⁴ and close-coupling⁵ truncated expansion of the wave function have been successful in reproducing not only the broad features of the cross section but in many cases the narrow features of the resonances as well. Thus, agreement between measured and calculated values of $A_{90^\circ}(1S \rightarrow 1S)$ below 10.2 eV must be viewed not only as a confirmation of theory but also as a vital check of the experimental method.

Above the $n=2$ threshold, however, calculations become increasingly difficult, reflecting the necessary inclusion of additional states (often synthesized pseudostates) in the wave-function expansion^{6,7} and the use of R -matrix techniques.⁸ These calculations, as well as those such as Glauber, Feddeev-Watson, second-order potential, eikonal, and eikonal-Born calculations,^{9,10} which are essentially high-energy approximations,

must be regarded as having questionable validity in the intermediate energy region (10–100 eV). Although many of the calculated values of the spin-averaged cross sections in this region are in good agreement with the measured values,^{11,12} such agreement does not guarantee that calculated values of the scattering amplitudes f and g are correct, as has been clearly demonstrated in the case of impact ionization.¹ Comparisons of theoretical and experimental values of polarization-dependent asymmetries are generally required for detailed tests of the various approximation methods.¹³

The experimental method which we used to determine $A_{90^\circ}(1S \rightarrow 1S)$ is essentially the same as that used for determining $A_{\text{tot}}(1S \rightarrow \epsilon l)$, the total cross-section asymmetry for impact ionization, described previously.¹ In brief, longitudinally polarized electrons are produced in a Fano-effect polarized electron source, in which circularly polarized uv light photoionizes an unpolarized Cs atomic beam. The helicity of the extracted electron beam is the same as the helicity of the incident light. Thus the electron polarization can be reversed by a 90° rotation of either a linear polarizer or a quarter-wave retardation plate, with the electron optics remaining unchanged.

As shown in Fig. 1 the electrons are transported at 1 keV into either the interaction branch or the Mott polarimeter branch. In the interaction branch the electrons are decelerated to the desired energy, the absolute scale being determined by the onset of ionization at 13.6 eV. Following the intersection with the hydrogen beam, the unscattered electrons are reaccelerated to 1 keV into a Faraday cup, and the total current is digitized by an electrometer and a voltage-to-frequency converter (VFC). Electrons elastically scattered at 90° are detected by an electron multi-

plier preceded by a filter lens which prevents inelastically scattered electrons from reaching the multiplier. The polar angle acceptance of the detection optics is 24° .

The atomic hydrogen beam is produced by effusion from a tungsten tube which is resistively heated to 2800 K to thermally dissociate the molecular gas. After collimation, the atomic $M_J = +\frac{1}{2}$ states of the partially dissociated beam are selected at high field in a permanent sextupole magnet and transported to the interaction region, with the atomic spins being adiabatically rotated either parallel or antiparallel to the electron beam, depending upon the orientation of a ~ 100 mG magnetic field in the interaction region. Appropriate shaping of the magnetic fields precludes Majorana depolarization.¹

Before entering the interaction chamber, the hydrogen beam is modulated by a 100-Hz tuning-fork beam chopper to permit real-time background subtraction. After leaving the chamber, the beam passes through a quadrupole mass analyzer (QMA) which monitors the relative amounts of atomic and molecular hydrogen. For incident electron energies above 13.6 eV, the ionization signal is monitored by a multiplier located along the hydrogen beam line downstream from the interaction region. The various experimental operating parameters are summarized in Table I.

Data acquisition is controlled by a PDP-15 computer. The digitized Faraday-cup output from the VFC is counted in a preset scaler which halts data taking after a preset charge has entered the cup. The electron events accumulated during the data interval are totaled on a pair of blind scalers corresponding to the 4-msec beam-on and 2-msec beam-off portions of each 10-msec hydrogen-beam chopper cycle. The H and H₂ quadrupole signals are similarly totaled as is the hydrogen-ion signal for incident electron energies above 13.6 eV. Also recorded for each data interval are the accumulated charge in the Faraday cup and the elapsed time of the interval. At the completion of the interval, the computer reads and clears the blind scalers, advances the quarter-wave plate by 90° , and reinitiates data accumulation. After ~ 40 revolutions of the quarter-wave plate the run is halted. Normally, a complete measurement at a given energy comprises sixteen runs corresponding to two revolutions of the linear polarizer in 90° steps for each of the two directions of the magnetic field in the interaction region.

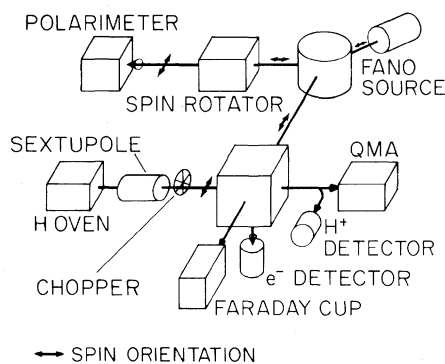

FIG. 1. Schematic diagram of experiment.

TABLE I. Experimental operating parameters.

Electron beam:	
Intensity	
at source exit	10 nA (av)
at interaction region	2 nA (av)
Polarization, P_e ^a	0.62–0.75 ($\pm 5\%$)
Energy spread (FWHM)	3.0 eV
Emittance at 1 keV	20 mrad cm
Hydrogen beam:	
Density at interaction region	$\sim 10^9$ cm ⁻³
Polarization, P_H , ^b	
at high field	0.99 ($\pm 1\%$)
at low field	0.50 ($\pm 4\%$)
Fraction of events, $1 - F_2$, attributed to atoms ^c	0.80–0.95 ($\pm 2\%$)
Collinearity factor, $\cos\alpha$	0.985 ($\pm 1.5\%$)
Background gas pressure	10^{-9} Torr
Detection solid angle:	
Electrons	0.14 sr
Ions	4π sr
Counting rates (16.9 eV):	
Electrons	2.2 s ⁻¹
Ions	29 s ⁻¹
Signal-to-noise ratios (16.9 eV):	
Electrons	1.3
Ions	7.0

^a Monitored periodically.^b Calculated, including hyperfine depolarization.^c Monitored continuously.

The real experimental asymmetry in the elastic electron signal, Δ_R , for each run is defined as

$$\Delta_R = (N_+ - N_- - B_+ + B_-) / (N_+ + N_- - B_+ - B_-), \quad (4)$$

where N_+ (B_+) is the sum of the beam-on (-off) electron events for quarter-wave-plate positions 0 and 2 corresponding to 0° and 180° , respectively, and N_- (B_-) is the sum of the beam-on (-off) electron events for the quarter-wave-plate positions 1 and 3 corresponding to 90° and 270° , respectively. In addition to the real asymmetry, two false asymmetries, Δ_{F1} and Δ_{F2} , can be constructed from quarter-wave-plate combinations $0+1-2-3$ and $0+3-1-2$, respectively, as tests of systematic errors. For both the real and false asymmetries, the values of Δ measured for each run are combined according to their statistical weights to give the final value for a given energy. The value of Δ_R so obtained is related to $A_{90^\circ}(1S \rightarrow 1S)$ according to

$$\Delta_R = P_e P_H |\cos\alpha| (1 - F_2) A_{90^\circ}(1S \rightarrow 1S), \quad (5)$$

where P_e and P_H are, respectively, the electron and atom polarizations, $\cos\alpha$ describes the collinearity of the ~ 100 mG magnetic field with the

TABLE II. Results of data analysis. Uncertainties are one standard deviation; those for A include systematic as well as statistical effects.

ENERGY E (eV)	REAL ASYMMETRY $A_{90^\circ}(1S \rightarrow 1S)$	FALSE ASYMMETRIES			
		Δ_{F1} (10^{-3})	Δ_{F2} (10^{-3})	$\chi^2(0)/\text{deg. freedom}$	
				Δ_{F1}	Δ_{F2}
4.1	+0.003(46)	+01(15)	+11(15)	10/16	16/16
6.0	-0.151(38)	+02(11)	-14(11)	13/18	15/18
8.3	-0.192(37)	+01(05)	+10(05)	12/24	37/24
10.0	-0.237(52)	00(05)	+02(05)	70/38	46/38
11.3	-0.276(52)	+01(13)	-02(13)	17/14	14/14
13.8	-0.336(64)	+24(16)	-13(16)	15/14	17/14
16.9	-0.285(55)	-08(13)	+06(13)	26/25	19/25
19.8	-0.193(53)	+14(14)	-28(14)	25/19	15/19
21.9	-0.212(55)	-10(16)	+15(16)	11/17	8/17
24.0	-0.114(66)	-24(18)	+26(18)	10/12	11/12
26.7	-0.200(42)	-26(12)	+07(12)	27/27	23/27
30.0	-0.177(62)	+18(19)	+10(19)	9/17	17/17
ALL RUNS		00(03)	+04(03)	245/241	238/241

electron beam, and F_2 is the fraction of events originating from molecules. As in the previous impact-ionization measurement, F_2 is determined from H_2 QMA signals and electron event rates obtained at a hydrogen oven temperature of ~ 1400 K where the beam is essentially molecular in composition.

The value of P_e is monitored periodically by Mott scattering during the experiment.¹ For P_H a calculated value is used, based upon the known properties of the sextupole magnet, the geometry of the hydrogen beam, and the effective magnetic moment of the hydrogen atom as a function of magnetic field.¹⁴

Above an incident electron energy of 13.6 eV, a similar analysis is performed for the ionization asymmetry. These new ionization asymmetry measurements will be published elsewhere.

The results of our measurements of A are tabulated in Table II and are shown in the upper portion of Fig. 2 with a number of theoretical calculations. Also shown in Fig. 2 are measurements of the spin-averaged cross section, $d\bar{\sigma}$.^{6,11,12} Since the energy resolution of the polarized beam precludes the observation of any resonance structure in A , all resonance details have been omitted for $d\bar{\sigma}$ as well as for A . As can be seen, although the measurements of $d\bar{\sigma}$ agree well with most of

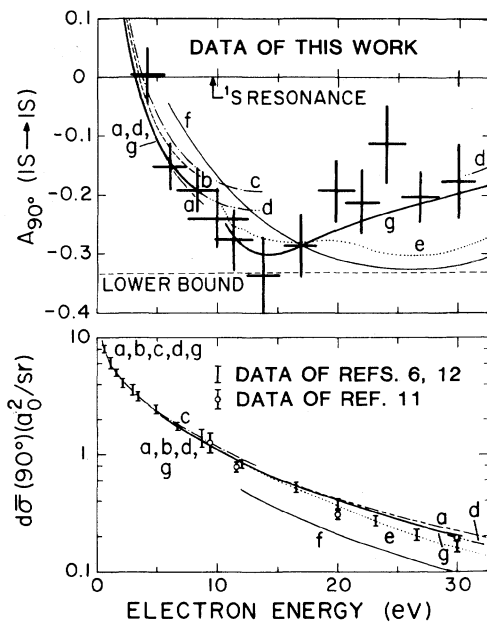

FIG. 2. Top: Measured values of $A_{90^\circ}(1S \rightarrow 1S)$ with representative theoretical predictions. Vertical error bars are one-standard-deviation uncertainties dominated by statistics; horizontal bars indicate the energy spread of the beam. References for the theoretical curves are a, Ref. 7; b, Ref. 3; c, Ref. 4; d, Ref. 15; e, Ref. 6; f, Ref. 9, and g, Ref. 16, resonance omitted. Bottom: Measurements by other researchers of the spin-averaged differential cross section $d\bar{\sigma}(90^\circ)$ compared with the same theoretical results as in the upper half of the figure.

the calculations, the measurements of A agree well only with the theoretical prediction of Ref. 16 over the entire energy range shown. It is interesting to note that our measurement of A at 13.8 eV is consistent with a value of $-\frac{1}{3}$, which is the lower bound on A and reflects pure triplet scattering.

We wish to acknowledge the contributions of G. Baum and J. S. Ladish and to thank J. Brosious, R. Broughton, D. Constantino, A. Disco, L. Trudell, and the Yale University Gibbs instrumentation shop staff for their technical assistance. This research was supported in part by the National Science Foundation under Grant No. PHY81-05035, by the City University of New York under Grant No. PSC-CUNY RF 13414, and by the Deutsche Forschungsgemeinschaft. One of us (M.S.L.) wishes to thank the Sloan Foundation for providing support in the form of an Alfred P.

Sloan Fellowship.

^(a)Permanent address: Measurex Corporation, Cupertino, Cal. 95014.

^(b)Permanent address: Bell Laboratories, Murray Hill, N.J. 07974.

^(c)Permanent address: Bell Laboratories, Holmdel, N.J. 07733.

¹M. J. Alguard *et al.*, Phys. Rev. Lett. **39**, 334 (1977); P. F. Wainwright *et al.*, Rev. Sci. Instrum. **49**, 571 (1978).

²J. Kessler, *Polarized Electrons* (Springer-Verlag, Berlin, 1976), pp. 87-95.

³C. Schwartz, Phys. Rev. **124**, 1468 (1961); M. K. Gaillitis, in *Proceedings of the Fourth International Conference on Electronic and Atomic Collisions, Université Laval, Quebec, 1965, Abstracts of Papers* (Science Bookcrafters, Hastings-on-Hudson, New York, 1965), p. 10; R. L. Armstead, Phys. Rev. **171**, 91 (1968); D. Register and R. T. Poe, Phys. Lett. **51A**, 431 (1975).

⁴A. Temkin and J. C. Lamkin, Phys. Rev. **121**, 788 (1961).

⁵P. G. Burke *et al.*, J. Phys. B **2**, 1142 (1969).

⁶J. Callaway and J. F. Williams, Phys. Rev. A **12**, 2312 (1975).

⁷W. C. Fon *et al.*, J. Phys. B **11**, 521 (1978).

⁸P. G. Burke *et al.*, J. Phys. B **4**, 153 (1971).

⁹G. Khayrallah, in *Proceedings of the Eleventh International Conference on Electronic and Atomic Collisions, Kyoto, 1979, Abstracts of Papers*, edited by K. Takayanagi and N. Oda (Society for Atomic Collision Research, Kyoto, 1979), p. 114.

¹⁰V. Franco, Phys. Rev. Lett. **20**, 709 (1968); F. W. Byron, Jr., and C. J. Joachain, J. Phys. B **7**, L212 (1974), and **10**, 207 (1977); J. C. Y. Chen *et al.*, Phys. Rev. A **7**, 2003 (1973); A.-L. Sinfailam and J. C. Y. Chen, Phys. Rev. A **5**, 1218 (1972); T. Scott and B. H. Bransden, J. Phys. B **14**, 2277 (1981); G. Foster and W. Williamson, Jr., Phys. Rev. A **13**, 2023 (1976).

¹¹P. J. O. Teubner *et al.*, Phys. Rev. A **9**, 2552 (1974); C. R. Lloyd *et al.*, Phys. Rev. A **10**, 175 (1974).

¹²J. F. Williams, J. Phys. B **8**, 1683 2191 (1975).

¹³M. S. Lubell, in *Coherence and Correlation in Atomic Collisions*, edited by H. Kleinpoppen and J. F. Williams (Plenum, New York, 1980), p. 663.

¹⁴Good agreement has been obtained in comparisons of such calculations with measured values in other experiments [M. J. Alguard *et al.*, Nucl. Instrum. Methods **163**, 29 (1979); V. W. Hughes *et al.*, Phys. Rev. A **5**, 195 (1972)]; moreover, the 47-cm length of the sextupole makes the degree of state selection quite insensitive to any uncertainties in the value of the pole-tip field strength.

¹⁵S. Geltman, Phys. Rev. **119**, 1283 (1960).

¹⁶B. L. Scott, Phys. Rev. **140**, A699 (1965); P. G. Burke and H. M. Schey, Phys. Rev. **126**, 147 (1962); P. G. Burke *et al.*, Phys. Rev. **129**, 1258 (1963).